



Come for a visit. Stay for a lifestyle.

Deck Design Guide

Municipality of Trent Hills
Building Services

66 Front Street South
Campbellford, ON K0L 1L0
building@trenthills.ca
705-653-1900

This guide is for informational purposes only. It is the responsibility of the applicant to ensure all information is complete, accurate and up to date

Revised November 2022

Introduction

This guide is for informational purposes only. It is the responsibility of the Applicant/Designer to review the building code and ensure all information is complete, accurate, and up to date.

Important Notes

The design and construction of a deck and/or Porch must comply with the Municipality of Trent Hills' Zoning By-Law as well as the Ontario Building Code (OBC). Special consideration must be taken if a deck is to support a hot tub or similar structures due to increased load.

Definitions

Deck: A raised platform that is attached to a dwelling. A deck will generally require a Building Permit and will require protective guards if the walking surface is greater than 24" (610mm) above finished grade.

Porch: A covered structure (enclosed or unenclosed_ that usually forms part of the entrance of a dwelling. Any Porch requires a Building Permit and will require protective guards if the walking surface is greater than 24" (610mm) above finished grade.

Patio: A platform at grade level that is usually constructed of concrete or stone. A Patio generally does not require a Building Permit unless it interferes with an existing structure.

Joist: Dimensional lumber places perpendicular to beam that frames the floor system

Beam: Laminated dimensional lumber that supports the joists

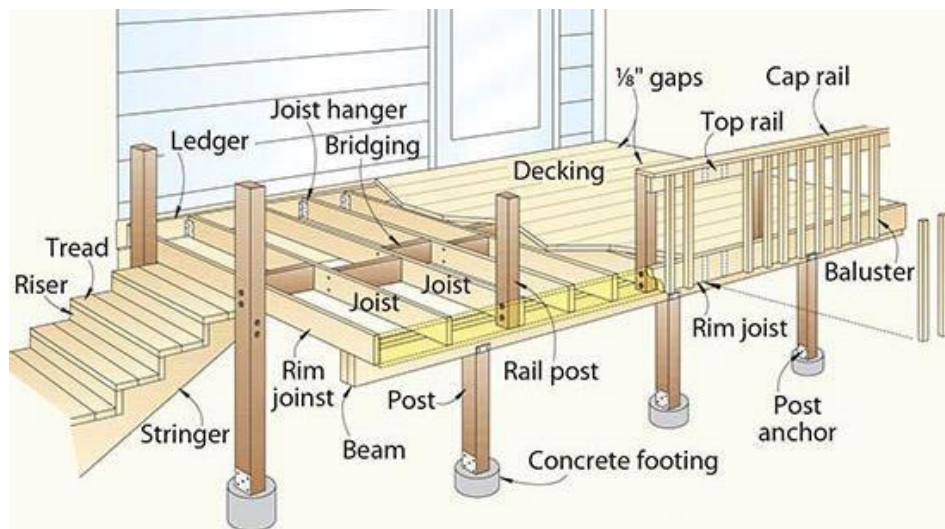
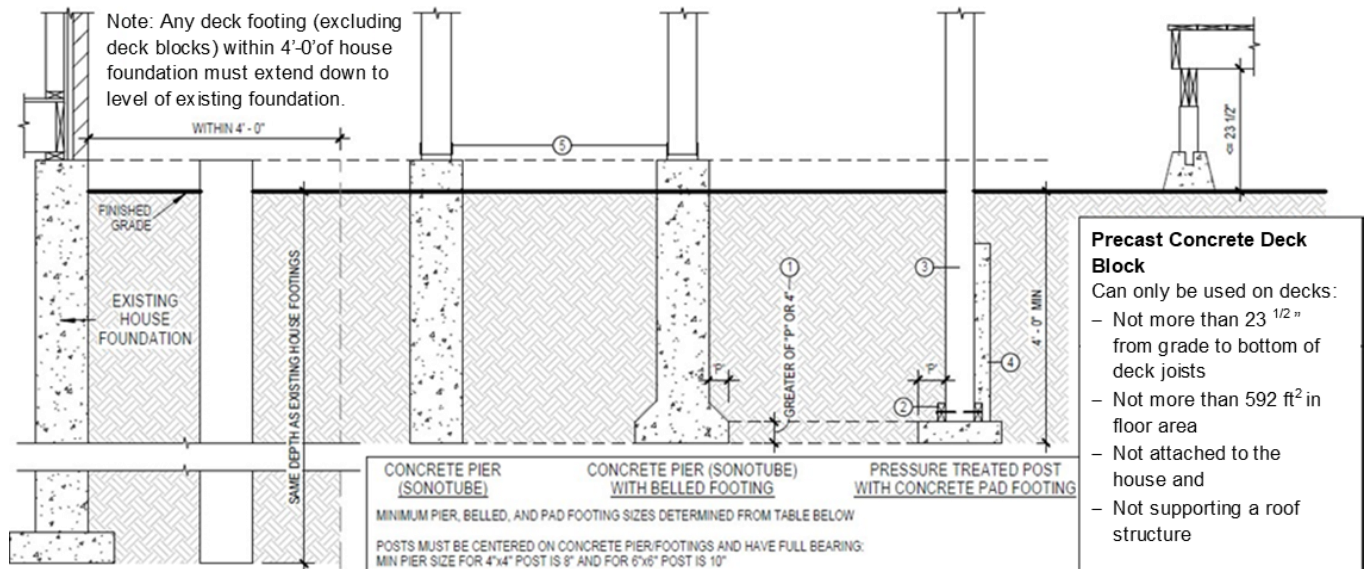

Figure 1a: Deck with labeled components.

Piers

Piers shall not be less than 10" in diameter. Under most circumstances it may be preferable to expand the lower portion of a smaller pier to achieve the required bearing area rather than use a larger pier. (Refer to Figure 2)



- (1) Minimum depth of belledpad footing is greater of 4"project "P" of the belledpad footing beyond the post/pier
- (2) Post bearing on pad footing required 2-2"x4" P.T. cleats fastened to opposite sides of the post with min. 3-31/2" galvanized nails to resist uplift. Cleats shall extend min. 2" past either side of post.
- (3) Buried pressure treated post must be rated for ground contact.
- (4) Optional concrete backfill around post.

Figure 2 - Footing Options

Size

Refer to the table on the next page for minimum footing sizes. The values in Table 1 are based on a soil bearing capacity of 10.9 psi (75 kPa). **Note:** Minimum required bearing area must be double where the soil bearing capacity is affected by a high-water table.

Concrete [OBC 9.3.1.6]

Piers shall consist of poured concrete with a minimum compressive strength of 5 MPa (2200psi) after 28 days

Height [OBC 9.15.2.3.(3)]

Piers shall not extend more than 3 times their width/diameter above grade

Depth [OBC 9.12.2.2]

Where a deck or porch is attached to a dwelling or required a guard, the minimum footing depth shall be 48" (1.2m). Frost protection for footings is not required if the deck meets **all** the following conditions:

- a) The deck is less than 24" (600 mm) in height,
- b) Is not attached to any structure,
- c) Is not supporting a roof (which includes a pergola/trellis), and
- d) The area of the deck is not more than 592 ft² (55m²)

Minimum Required Footing Area (ft ²)								
		Supported Joist Length* (ft)						
		4'-0"	5'-0"	6'-0"	7'-0"	8'-0"	9'-0"	10'-0"
Beam Length (ft)	4'-0"	8" x 8" (10" dia.)	9" x 9" (10" dia.)	10" x 10" (12" dia.)	10" x 10" (12" dia.)	11" x 11" (12" dia.)	12" x 12" (12" dia.)	13" x 13" (14" dia.)
	4'-6"	8" x 8" (10" dia.)	9" x 9" (10" dia.)	10" x 10" (12" dia.)	11" x 11" (12" dia.)	12" x 12" (12" dia.)	13" x 13" (14" dia.)	13" x 13" (14" dia.)
	5'-0"	9" x 9" (10" dia.)	10" x 10" (12" dia.)	11" x 11" (12" dia.)	12" x 12" (12" dia.)	13" x 13" (14" dia.)	13" x 13" (14" dia.)	14" x 14" (16" dia.)
	5'-6"	9" x 9" (10" dia.)	10" x 10" (12" dia.)	11" x 11" (12" dia.)	12" x 12" (12" dia.)	13" x 13" (14" dia.)	14" x 14" (16" dia.)	15" x 15" (18" dia.)
	6'-0"	10" x 10" (12" dia.)	11" x 11" (12" dia.)	12" x 12" (12" dia.)	13" x 13" (14" dia.)	14" x 14" (16" dia.)	15" x 15" (18" dia.)	16" x 16" (18" dia.)
	7'-0"	10" x 10" (12" dia.)	12" x 12" (12" dia.)	13" x 13" (14" dia.)	14" x 14" (16" dia.)	15" x 15" (18" dia.)	16" x 16" (18" dia.)	17" x 17" (20" dia.)
	8'-0"	11" x 11" (12" dia.)	13" x 13" (14" dia.)	14" x 14" (16" dia.)	15" x 15" (18" dia.)	16" x 16" (18" dia.)	17" x 17" (20" dia.)	18" x 18" (20" dia.)
	9'-0"	12" x 12" (12" dia.)	13" x 13" (14" dia.)	15" x 15" (18" dia.)	16" x 16" (18" dia.)	17" x 17" (20" dia.)	18" x 18" (20" dia.)	19" x 19" (22" dia.)
	10'-0"	13" x 13" (14" dia.)	14" x 14" (16" dia.)	15" x 15" (18" dia.)	17" x 17" (20" dia.)	18" x 18" (20" dia.)	19" x 19" (22" dia.)	20" x 20" (22" dia.)
	12'-0"	14" x 14" (16" dia.)	14" x 14" (16" dia.)	17" x 17" (20" dia.)	17" x 17" (20" dia.)	20" x 20" (22" dia.)	20" x 20" (22" dia.)	21" x 21" (24" dia.)
	14'-0"	15" x 15" (18" dia.)	16" x 16" (18" dia.)	18" x 18" (22" dia.)	19" x 19" (22" dia.)	21" x 21" (24" dia.)	21" x 21" (N/A)	24" x 24" (N/A)
16'-0"	16" x 16" (18" dia.)	16" x 16" (18" dia.)	20" x 20" (22" dia.)	20" x 20" (22" dia.)	23" x 23" (N/A)	23" x 23" (N/A)	25" x 25" (N/A)	

*Supported Length means half the sum of the joists supported by the beam & ledger board plus any cantilever (see Figure 1b)

Columns

Size [OBC 9.17.4.1.(2)]

Wood columns shall be not less than 7 ¼" Ø (184mm Ø) for round columns and 5 ½" x 5 ½" (140 mm x 140 mm) for square or rectangular columns.

Anchorage [OBC 9.23.6.2.]

Columns shall be directly fastened to their supports as well as to the framing members for which they are supporting to resist uplift and lateral movement.

Ledger Board Size

A Ledger Board shall consist of the same nominal sized lumber as the deck joists and shall contain joist hangers to support the joists. These hangers shall be coated to prevent corrosion and installed as per the manufacturer's specifications.

Anchorage

Anchor Bolts shall consist of for solid concrete or concrete filled masonry or carriage bolts with nuts and washers into suitable structural lumber spaced not more than 16" on centre (staggered) (Refer to Figure 3). Connectors shall be embedded at least 4" (100mm) into solid concrete, concrete filled masonry, or suitable structural lumber. (Refer to Figure 4a and 4b)

Note: Anchor bolts shall not be attached to hollow masonry or brick veneer

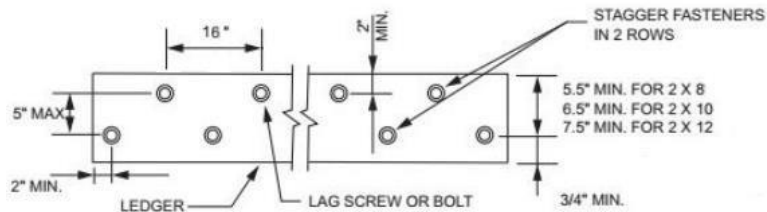

Figure 3 – Ledger Board Fastener Spacing and Clearances

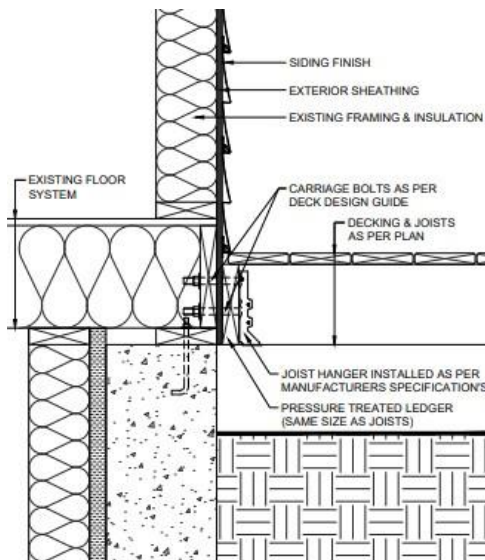

Figure 4a - Deck Connection with Siding

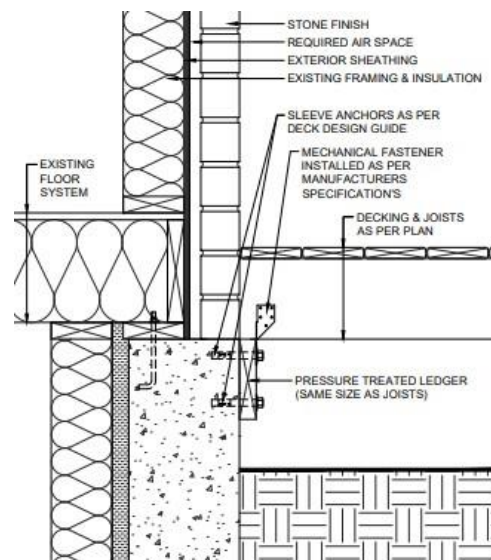

Figure 4b - Deck Connection with Brick

Beams

Bearing [OBC 9.17.4.1. and 9.23.8.1.]

Built-up beams shall have not less than 3.5" (89mm) of bearing and be fully supported over their width. Maximum beam cantilever is 12" (Refer to Figure 1)

Built-up wood [OBC 9.23.8.3.]

Where individual members are butted together to form a joint, the joint must occur over a support (Refer to Figure 5a and 5b). Built up beams shall be nailed together with a double row of nails not less than 3.5" (89mm) in length, not more than 18" (450mm) apart, and not more than 4" (100mm) from the end. (Refer to Figure 6). Refer to the table below for maximum built-up beam sizes and length (¹spans based on Spruce-Pine-Fir (SPF) Grade No. 1 or No. 2)

		Maximum Beam Span ¹ , (ft)					
		Size of Built-up Beam					
		3-2x8	4-2x8	3-2x10	4-2x10	3-2x12	4-2x12
Supported Length* (ft)	7'-10"	10'-0"	11'-0"	12'-10"	14'-2"	15'-0"	17'-2"
	9'-10"	9'-4"	10'-3"	11'-6"	13'-1"	13'-5"	15'-5"
	11'-9"	8'-7"	9'-8"	10'-6"	12'-2"	12'-2"	14'-1"
	13'-9"	8'-0"	9'-2"	9'-9"	11'-3"	11'-4"	13'-1"
	15'-9"	7'-5"	8'-7"	9'-1"	10'-6"	10'-7"	12'-2"
	17'-8"	7'-0"	8'-1"	8'-7"	9'-11"	10'-0"	11'-6"
	19'-8"	6'-8"	7'-8"	8'-2"	9'-5"	9'-5"	10'-11"

*Supported Length means half the sum of the joists supported by the beam & ledger board plus any cantilever (see Figure 1)

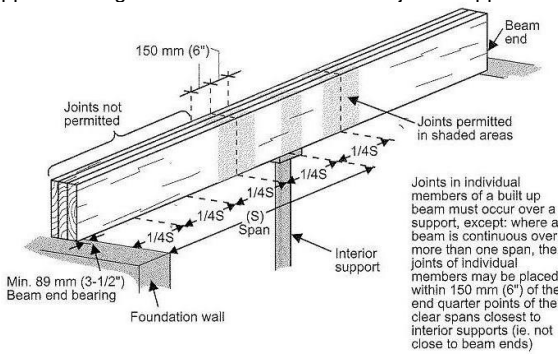

Figure 5a - Built-Up Beam Joints

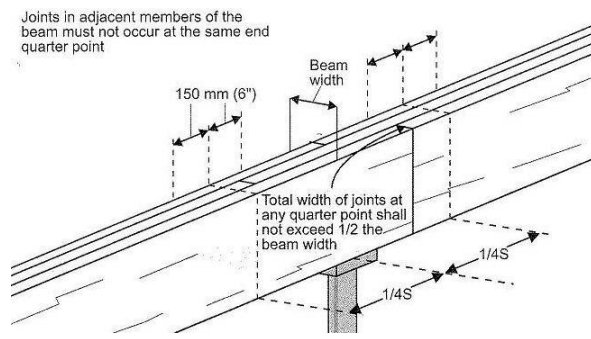

Figure 5b - Built-Up Beam Joint Support

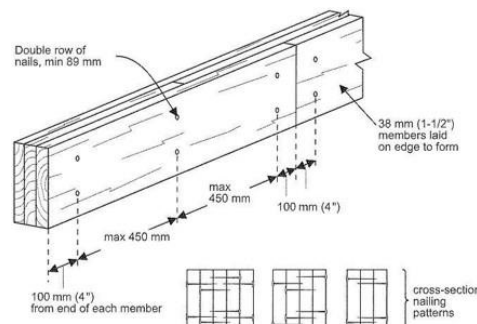

Figure 6 - Built-Up Beam Nailing

Note: as an alternative to nailing, bolt members together with min. 1/2" (12.7mm) diameter bolts with washers and spaced 4' (1.2m) max. o.c. with end bolts not more than 2' (600 mm) from ends of the members

Joists

Bearing [OBC 9.23.3.4.(1), 9.23.9.1 – 9.23.9.3]

Floor joists may be supported on either the top of a built-up beam or in a joist hanger coated to prevent corrosion and installed as per the manufacturer's specifications. At no time shall the minimum bearing of joists be less than 1 ½" (38 mm). Each joist must be mechanically fastened to the supporting member with two 3 ¼" (82mm) nails. Refer to the table below for maximum size and spacing of joists. (*spans based on Spruce-Pine-Fir (SPF) Grade No. 1 or No. 2)

Maximum Joist Span*, (ft)				
		12" on centre	16" on centre	24" on centre
Joist Size	2x6	10'-3"	9'-4"	8'-2"
	2x8	12'-6"	11'-9"	10'-8"
	2x10	14'-6"	13'-8"	12'-10"
	2x12	16'-5"	15'-5"	14'-6"

Note: The use of floor joists less than 2x8 is not recommended as it does not allow for proper attachment of railings

Cantilever [OBC 9.23.9.9.]

2"x8" (38mmx184mm) joists shall not be cantilevered more than 16" (400 mm) beyond their supports. Joists larger than 2x8 shall not cantilever more than 24" (600 mm) beyond their supports.

Bridging or Blocking [9.23.9.4. (2), 9.23.3.4. (1)]

Where joists are greater than 6'-11" (2.1 m) cross bridging or solid blocking shall be provided at mid span. Cross bridging or solid blocking shall be:

- 1x3 (19 mm x 64 mm) cross bridging,
- 2x2 (38 mm x 38 mm) cross bridging or
- solid blocking the same size as the joists

Bridging shall be fastened with two 2 ¼" (57 mm) nails at each end.

Decking

Plank type decking less than or equal to 7.25" (184 mm) wide shall be fastened with two galvanized framing nails 2" (51 mm) in length or two 1 ¾" (45 mm) coated screws. Decking shall be at least 11/16" (17 mm) thick when placed on joists spaced 16" (400 mm) on centre or less and ¾" (19 mm) thick when placed on joists spaced 24" (600 mm) on centre.

Fasteners

All fasteners used must be properly treated or coated to prevent corrosion. Equivalent screws may be used in lieu of nails so long as they provide equal strength.

Stairs [OBC 9.8]

Shall have a width not less than 36" (900 mm). Risers shall be a minimum of 4 7/8" (125 mm) and a maximum of 7 7/8" (200 mm). Treads shall be a minimum of 9.25" (235 mm) and a maximum of 14" (355 mm). Stringers shall consist of a minimum 2x10 (38 mm x 235 mm) lumber. (Refer to Figure 7 & 8)

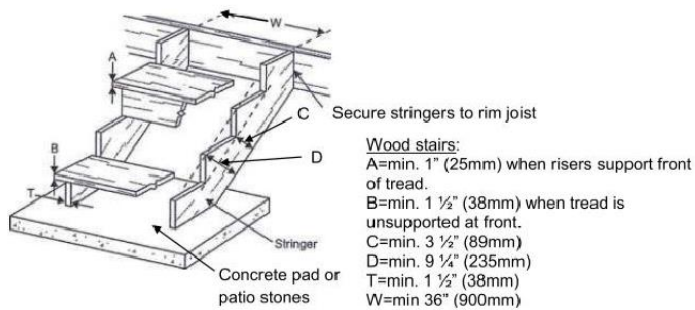

Figure 7 - Stair Detail

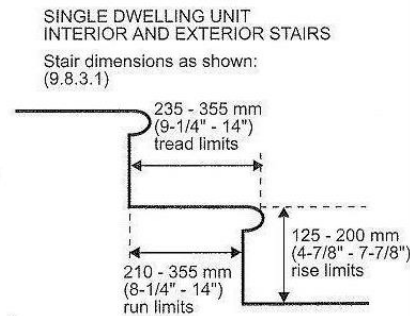

Figure 8 - Stair Dimension

Railings

Railing designs and supports shall conform to Supplementary Standard SB-7 of the Ontario Building Code. Railings shall be required for interior stairs that have more than two steps, and exterior stairs that have more than three steps.

Height of Guards [OBC 9.8.8.3.]

Exterior guards are required where the walking surface is more than 24" (600 mm) above grade. See table below for minimum guard heights. If a bench is incorporated into the guard then the required height is measured from the bench surface.

Height above Finished Grade	Minimum Guard Height
0 – 24"	Not Required
25" – 5'-11"	36"
6'-0" – 32'-8"	42"
32'-9" +	59"

Openings [OBC 9.8.8.5]

Opening in guard balusters shall be of a size that will prevent the passage of a spherical object having a diameter of 4" (100 mm).

Guards shall be designed so that no member, attachment, or opening will facilitate climbing.

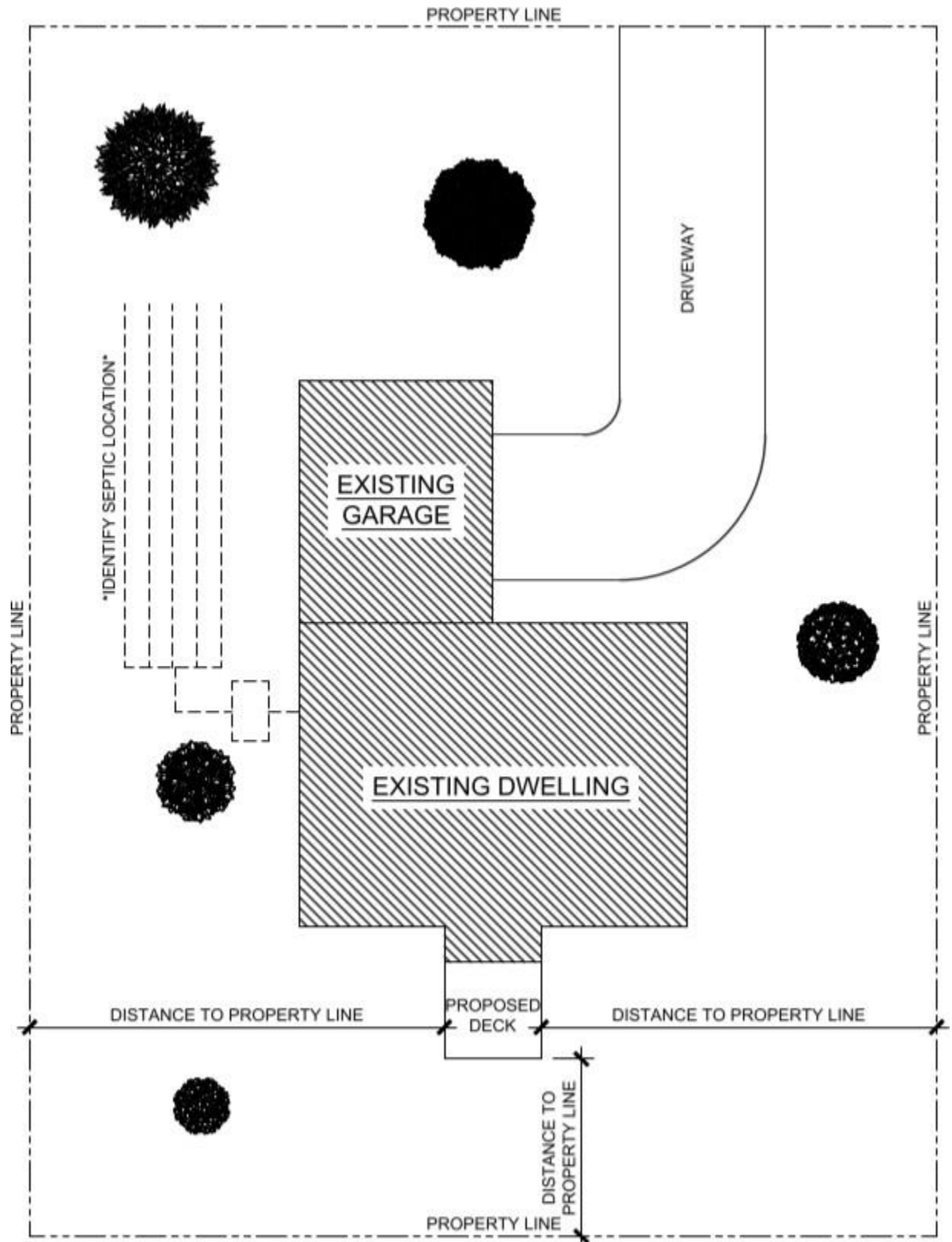

Figure 9 Sample Site Plan

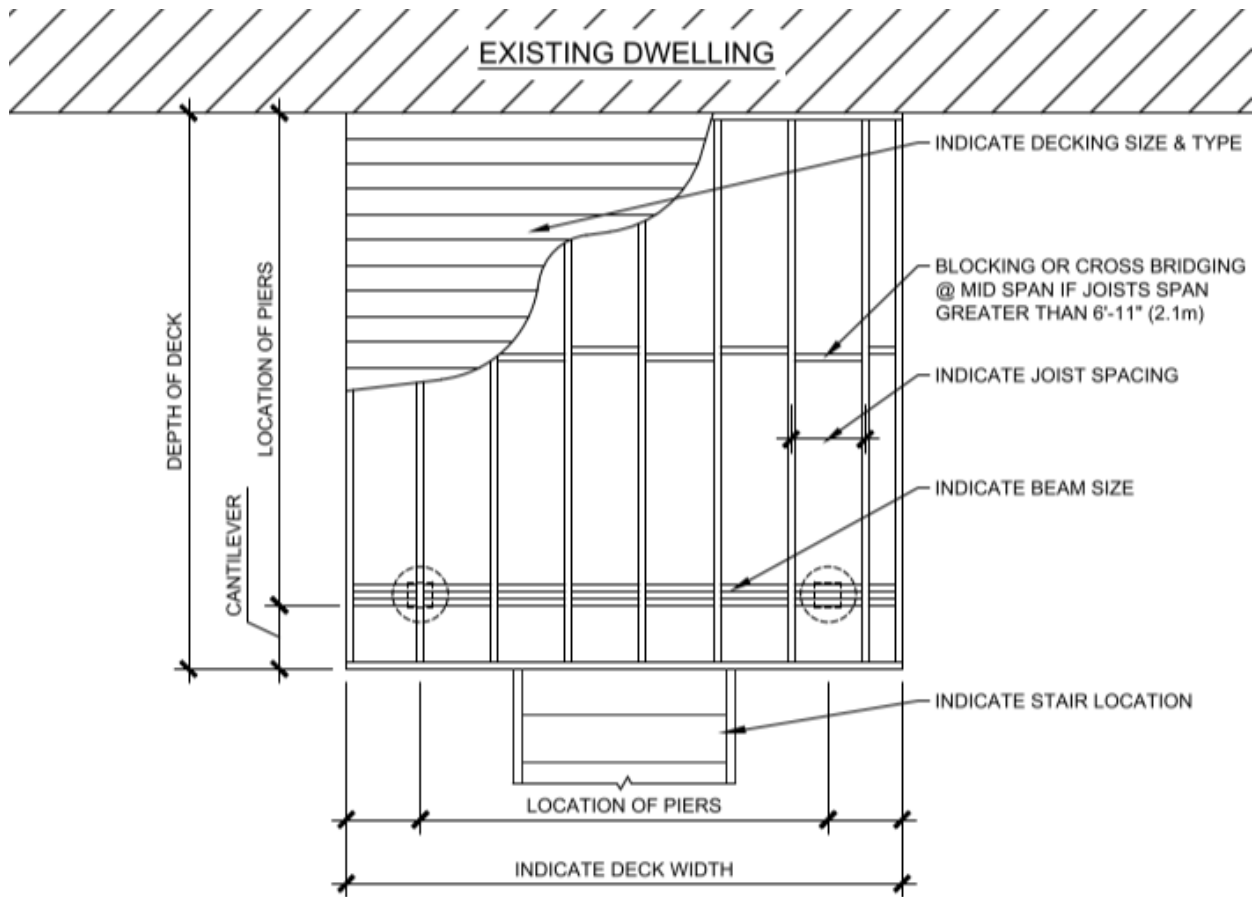

Figure 10 Sample Floor Plan

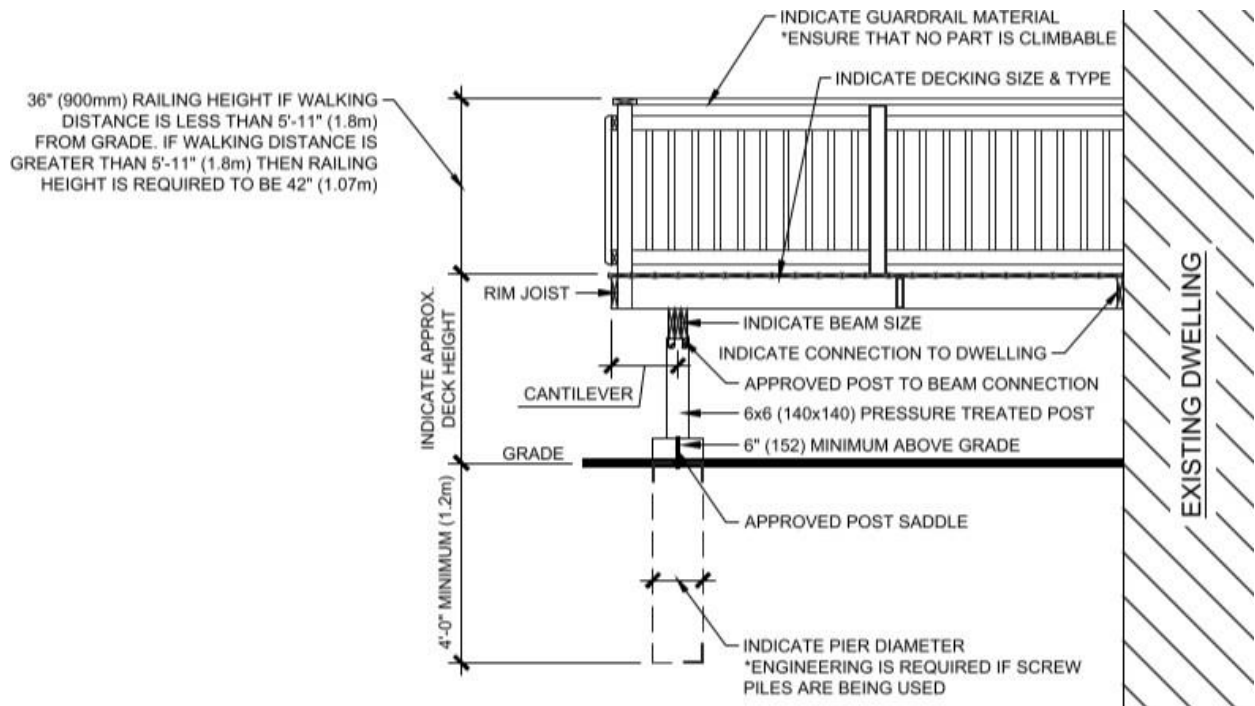

Figure 11 Sample Deck Section